

Installation and Commissioning Manual Solarstation SenCon Basic



Contents

1 General information	3
1.1 About these instructions.....	3
1.2 About this product.....	3
1.3 Designated use.....	4
2 Safety instructions.....	5
3 Assembly and installation [specialist]	7
4 Commissioning [specialist]	9
4.1 Flushing and filling the solar circuit	10
4.2 Preparations before flushing	12
4.3 Flushing and filling	12
4.4 Adjustment of the solar installation	15
5 Maintenance [specialist]	16
5.1 Draining the solar installation	16
5.2 Deinstallation	17
6 Spare parts	17
7 Technical data and pressure drop characteristic	18
8 Function: check valves	20
9 Commissioning report	22

1. General information



Carefully read these instructions before installation and commissioning.
Save these instructions in the vicinity of the installation for future

1.1 About these instructions

This manual describes the function, installation, commissioning and operation of the SenCon Basic solar stations. The chapters called [specialist] are intended for specialists only.

For other components of the solar thermal system such as collectors, tanks, expansion tanks and controllers, please observe the instructions of the corresponding manufacturer.

1.2 About this product

The station is a premounted fitting group checked for leakage used to circulate the solar fluid in the solar circuit. It is mounted on a wall bracket and fixed with clips. The solar station is optionally equipped with a premounted controller in an insulating shell. It contains important fittings and safety devices for the operation of the installation:

- Ball valves in the flow and return line with exchangeable spindle
- Check valves in the flow and return ball valves
- Thermometers in the flow and return
- Pressure gauge to display the installation pressure
- Flowmeter to display the flow rate
- Ball valve to reduce the flow rate
- Solar pressure relief valve
- Airstop to easily vent the solar circuit
- Flush and fill connections

1.3 Designated use

The solar station may only be used as a pump station in the solar circuit taking into

consideration the technical limit values indicated in these instructions. Due to its design the station must be mounted and operated as described in these instructions! Improper usage excludes any liability claims.

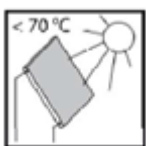
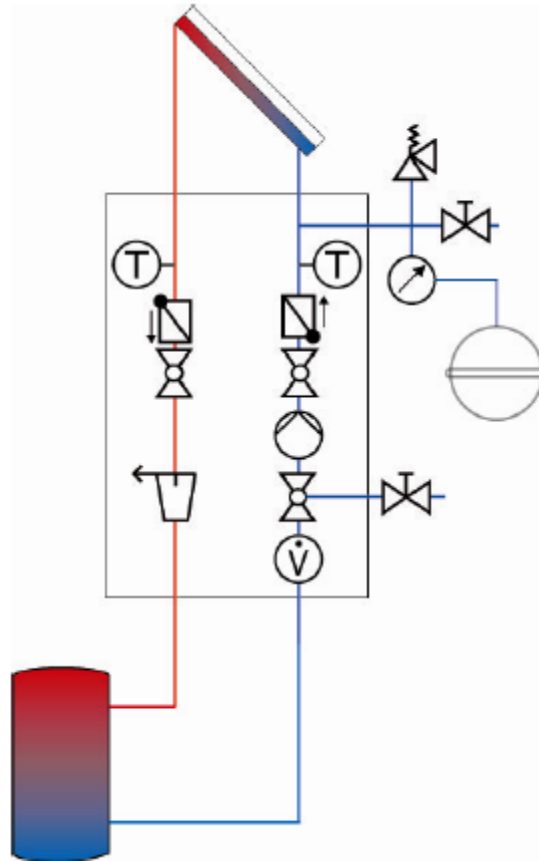

When the sun shines, the collectors can become very hot. The solar fluid in the circuit can heat up to more than 100 °C. Only flush and fill the solar when the collector temperatures are below 70 °C.

2. Safety instructions

The installation and commissioning as well as the connection of electrical components require technical knowledge commensurate with a recognized vocational qualification as a fitter for plumbing, heating and air conditioning technology, or a profession

requiring a comparable level of knowledge [specialist]. The following must be observed during installation and commissioning:

- relevant local and national regulations
- accident prevention regulations of the professional association
- instructions and safety instructions mentioned in this manual

	WARNING
	<p>Danger of scalding due to vapour escape!</p> <p>With pressure relief valves there is risk of scalding due to vapour escape. During installation, check the local conditions and if a discharge line must be connected to the safety group.</p> <ul style="list-style-type: none"> ➤ Observe the instructions regarding the pressure relief valve.

	CAUTION
	<p>Personal injury and damage to property due to overpressure!</p> <p>By closing the two ball valves in the primary circuit you isolate the pressure relief valve from the heat exchanger. Arise in temperature in the storage tank will cause high pressures and could result in personal injury or damage to property!</p> <ul style="list-style-type: none"> ➤ Only close the ball valves for service and maintenance.

NOTICE

Material damage due to mineral oils!

Mineral oil products cause lasting damage to seals made of EPDM, whereby the sealant properties are lost. We do not assume liability nor provide warranty for damage to property resulting from sealants damaged in this way.

- It is imperative to avoid that EPDM gets in contact with substances containing mineral oils.
- Use a lubricant based on silicone or polyalkylene and free of mineral oils such as Unisilikon L250L and Syntheso Glep 1 of the Klüber company or a silicone spray.

NOTICE

Material damage due to high temperatures!

Install the fitting group at a sufficient distance from the collector field, since the solar fluid may be very hot near the collector. It may be necessary to install an intermediate tank in order to protect the expansion tank.

3. Assembly and installation [specialist]

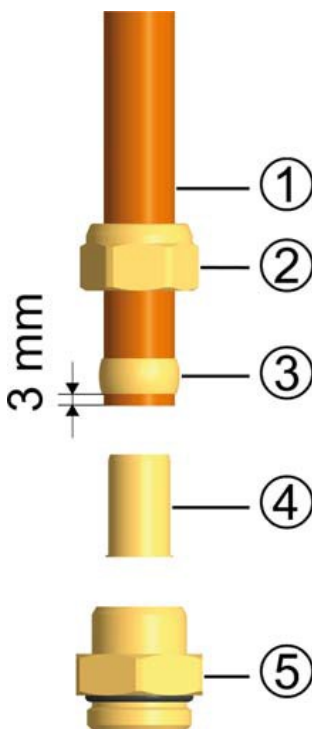

Accessories: compression fitting

1. Push the union nut (2) and the cutting ring (3) onto the copper pipe (1). The pipe must protrude at least 3 mm from the cutting ring in order to ensure the force transmission and the sealing.
2. Insert the support sleeve (4) into the copper pipe.
3. Insert the copper pipe with the plugged-on individual parts (2), (3) and (4) all the way into the housing of the compression fitting (5).
4. First screw the union nut (2) manually.
5. Tighten the union nut (2) by rotating one full turn.

Secure the housing of the compression fitting (5) against distort in order to avoid damaging the sealing ring.

Not included in the scope of delivery!

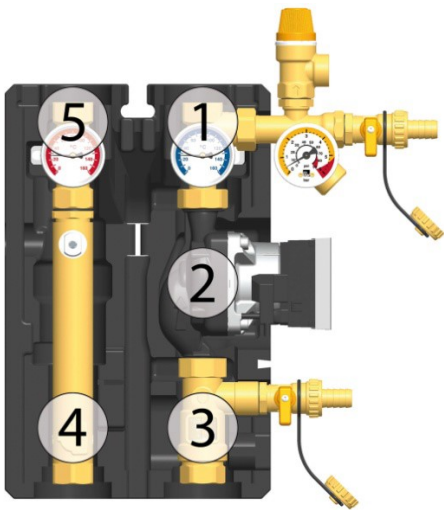

1. Remove the station from the packaging.
2. Remove the insulating front shell.

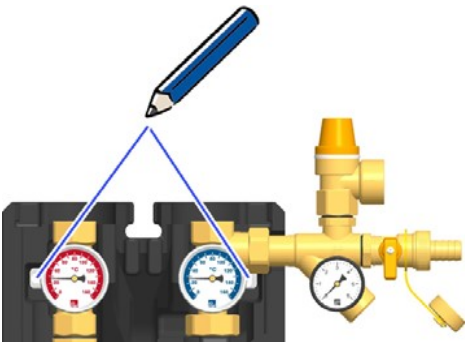

3. Copy the mounting holes of the solar station besides the thermometers to the mounting surface.
4. Drill the holes and mount the solar station to the wall with the enclosed wall plugs and screws.

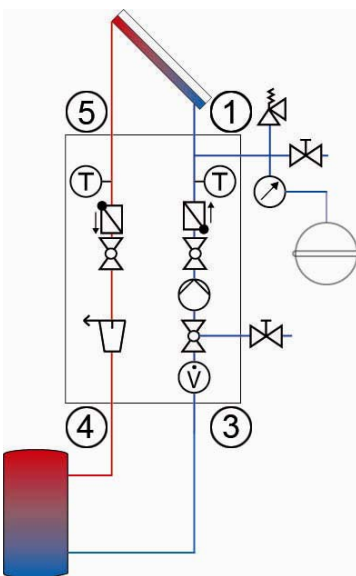

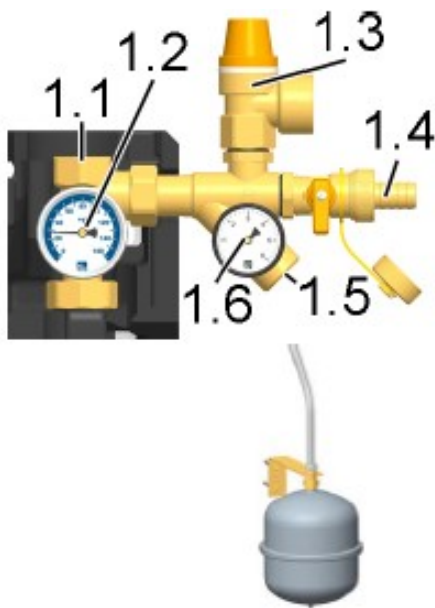

5. Connect the solar station to the installation
 - ⑤ flow from the collector field
 - ① return to the collector field
 - ④ flow to the storage tank
 - ③ return from the storage tank
 All screw connections have $\frac{3}{4}$ " internal threads.



6. Connect the pipe for the expansion tank below the pressure gauge [1.5] and fix the bracket for the expansion tank.
7. Adapt the initial pressure of the expansion tank to the installation and connect the expansion tank. Please observe the separate instructions regarding the expansion tank!
8. Check all thread connections and tighten them if necessary.

Optionally available!

	 WARNING
	<p>Risk to life and limb due to electric shock!</p> <ul style="list-style-type: none"> ➤ Prior to commencing electrical work on the controller, pull the mains plug! ➤ Only after completing all installation work as well as the flushing and filling, the mains plug of the controller can be plugged into a socket. Thus, an unintentional start of the motors is avoided.

9. Connect the pump and the sensors to the controller.

NOTICE

Note regarding the connection of the pump

Connect the cable for the PWM signal to the controller.

- Please observe the correct relay attribution: f. ex. R1 to PWM A; R2 to PWM B.
- Please observe the correct form of the PWM signal: f. ex. PWM2; PWM Solar.

4. Commissioning [specialist]

Please observe the following safety instructions regarding the commissioning of the station:

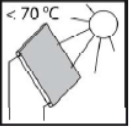
 	<p style="text-align: center;">WARNING</p> <p>Risk of burning and scalding!</p> <p>The fittings can heat up to more than 100 °C. Therefore, it is not allowed to flush or fill the system if the collectors are hot (intense solar radiation). Please note that hot solar fluid can leak from the pressure relief valves in case of too high system pressure!</p> <p>During venting the solar fluid may escape as vapour and cause scalding!</p> <ul style="list-style-type: none"> ➤ Only flush and fill the installation when the collector temperatures are below 70 °C.
---	--

NOTICE

Risk of frost!

It often happens that the solar thermal system cannot be completely drained after flushing. Thus, there is risk of frost damage when flushing with water. Therefore, do only use the solar fluid used later to flush and fill the solar installation.

- Use a water and propylene glycol mixture with max. 50% of propylene glycol as a solar fluid.

NOTICE

Note regarding the sequence of commissioning

When putting the system into operation, first fill the heating circuit and then the solar circuit. This guarantees that heat that may possibly be absorbed by the collectors during commissioning can be dissipated.

NOTICE

Note regarding the expansion tank

To prevent that dirt particles of the solar system are washed into the expansion tank, some manufacturers recommend to disconnect the expansion tank from the solar circuit during flushing and filling. Please observe the instructions of the manufacturer on this topic.

4.1 Flushing and filling the circuit

The fill and drain valves necessary to flush and fill the installation are integrated in the solar station.

To prevent that the dirt particles of the solar system are washed into the expansion tank, some manufacturers recommend to disconnect the expansion tank from the solar circuit during flushing and filling. Please observe the instructions of the manufacturer on this topic.

To flush the dirt particles out of the installation, only use flush and fill stations with fine filters.

Ball valve with integrated flow check valve

(Normal flow direction in the figure: downwards)

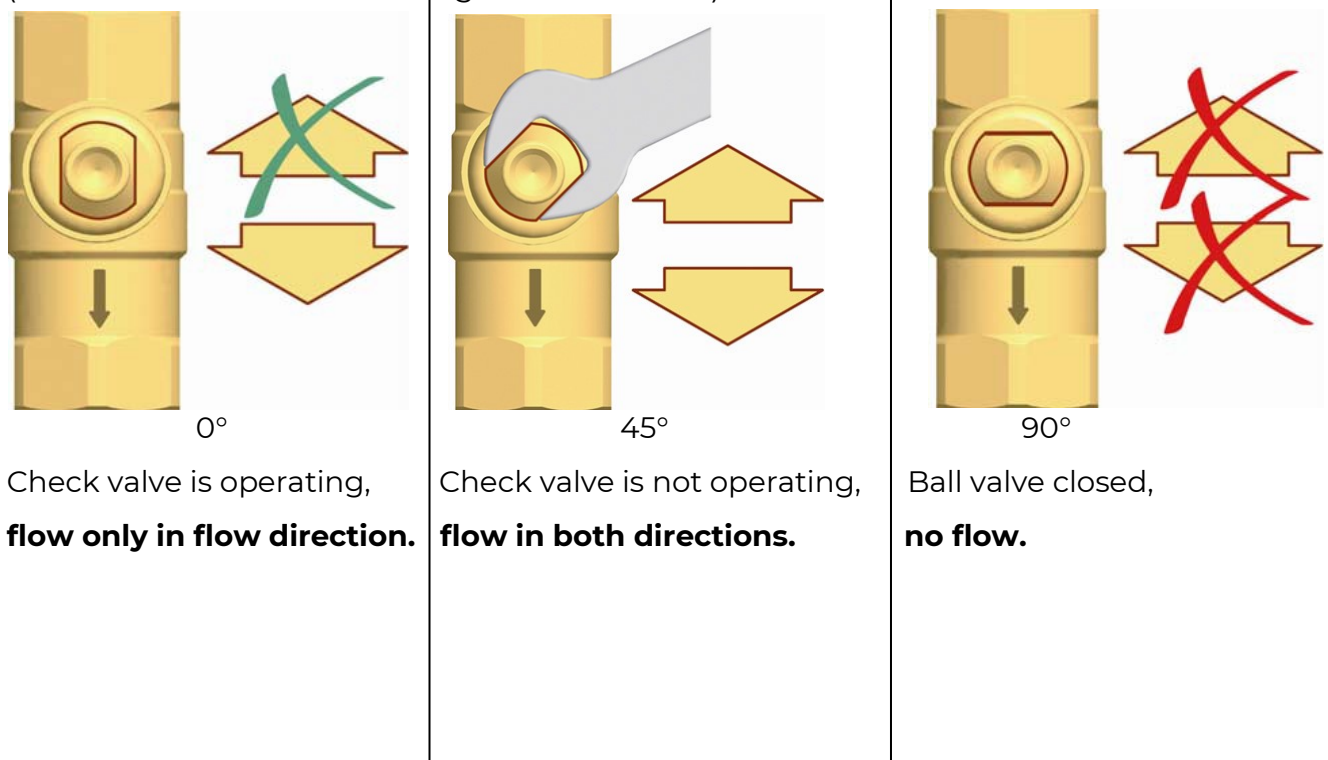



Airstop

The Airstop with manual vent valve is used to vent the solar installation. To ensure a perfect venting of the solar circuit, the flow velocity in the flow line must be at least 0.3 m/s.



Pipe diameter [mm]		Flowrate at 0,3 m/s	
∅ outside	∅ inside	l/h	l/min
15	13	~ 143	~ 2,4
18	16	~ 217	~ 3,6
22	20	~ 339	~ 5,7

The air liberated from the solar fluid is collected in the upper part of the Air stop and can be released via the vent plug [4.2]

		WARNING
	<p>Danger of scalding due to vapour escape!</p> <p>The escaping fluid can heat up to more than 100 °C and causes scalding.</p> <ul style="list-style-type: none"> ➤ Carefully open the vent plug and close it again as soon as medium escapes. 	

Venting the solar installation after commissioning

At the beginning, vent the solar installation daily and then weekly or monthly, depending on the quantity of vented air. Thus, an optimum operation of the solar installation is ensured. Check the system pressure after venting and increase it to the specified operating pressure, if necessary.

4.2 Preparations before flushing

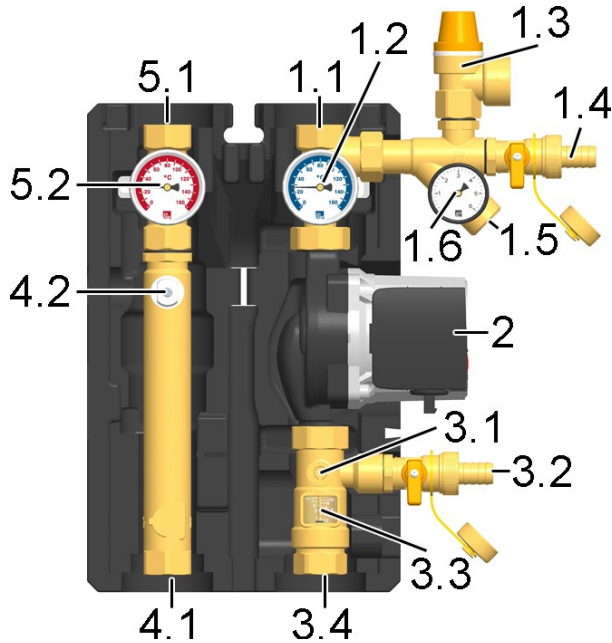

The solar circuit is flushed in the direction Of flow.

1. Disconnect the expansion tank from the solar installation. Please observe the instructions of the manufacturer on this topic!
2. Turn the check valve in the flow ball valve [5.2] into operating position (0°, see page 11).
3. Close the return ball valve [1.2] (90°, see page 11).
4. The ball valve [3.1] must be open.
5. Connect the fill station to the solar station:
 - Pressure hose to the fill valve [1.4]
 - Flush hose to the drain valve [3.2]

4.3 Flushing and filling

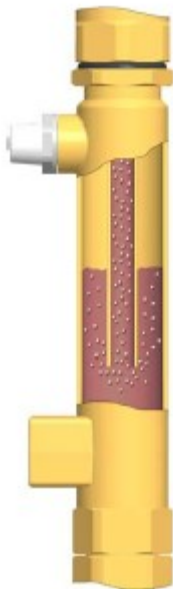

1. Open the fill and drain valves [1.4][3.2].
2. Put the flush and fill station into operation and flush the installation until clear solar fluid exits. Vent the solar installation several times at the vent plug of the airstop[4.2] until the solar fluid exits without bubbles (see page 12).

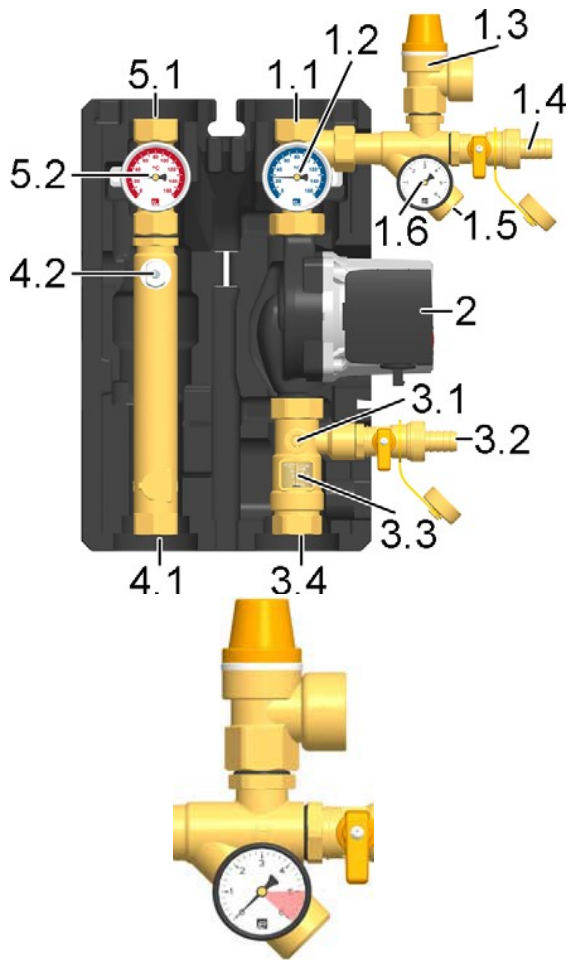

Check the pressure relief valve (6bar)!

3. Slowly open the return ball valve [1.2] (0°, see page 11) to vent the pump section.
4. Close the drain valve [3.2] while the filling pump is running and increases the system pressure to maximum 5 bars. The system pressure is displayed on the pressure gauge. Close the fill valve [1.4] and switch off the pump of the flush and fill station.
5. Check the pressure gauge to see if the system pressure decreases and eliminate leaks if necessary.
6. Reduce the pressure at the drain valve [3.2] to the operating pressure of the installation.
7. Connect the expansion tank to the solar circuit and set the operating pressure of the solar system by means of the flush and fill station (for the required operating pressure, see instructions of the expansion tank).
8. Close the fill and drain valves [1.4|3.2].
9. Turn the check valve in the return ball valve [1.2 | 5.2] into operating position (0°, see page 11).

	<p style="text-align: center;">WARNING</p>
<p>Risk to life and limb due to electric shock!</p> <ul style="list-style-type: none"> ➤ Check if the sensors and the pumps are properly connected to the controller and if the controller housing is closed. Only then, the mains plug of the controller can be plugged into a socket. 	

10. Connect the controller (not included in the scope of delivery) to the mains and set the pump of the solar circuit in the manual mode to ON according to the controller instructions. Let the pump of the solar circuit run at maximum rotation speed for at least 15 minutes.

Meanwhile vent the solar installation several times at the vent plug of the Air stop until the solar fluid exits without bubbles (see page 12).

If necessary, increase the system pressure to the operating pressure.



11. Remove the hoses of the flush and fill station and screw the sealing caps onto the fill and drain valves. The sealing caps only serve to protect the valves against dirt. They are not designed to take up high system pressures. The ball valves must be closed to guarantee tightness

4.4 Adjustment of the solar installation

Please observe the specifications of the collector manufacturer for the correct adjustment of the flow rate.

Scale

0,5-15 l/min

Reading edge =

Top edge of the float

Example: about 4 l/min



1. Set the desired maximum flow rate at the controller
2. Mount the insulating front shell to the station.
3. Set to controller automatic mode (see controller manual).

Recommended values for the flow rate (l/min) and the dimensioning of the pipes				
Number of vacuum tubes	Pipe diameter mm	with speed control		without speed
		100 %	50 %	
30	18	3,00	1,50	2,00 - 2,50
40	18	3,50	1,75	2,50 - 3,00
50	22	4,50	2,25	3,00 - 4,00
60	22	5,00	2,50	4,00 - 4,50
70	22	6,00	3,00	4,50 - 5,00
80	22	6,50	3,25	5,50 - 6,00
90	22	7,50	3,75	6,00 - 7,00
100	22	8,00	4,00	7,00 - 7,50
120	28	9,50	4,75	8,00 - 9,00
140	28	11,00	5,50	9,50 - 10,50

5. Maintenance [specialist]

5.1 Draining the solar installation

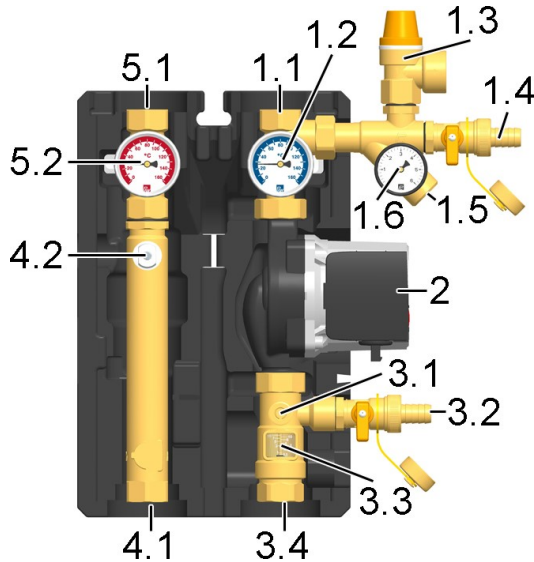

1. Switch off the controller and make sure that a restart is not possible.
2. Open the check valves in the flow and return ball valve [5.2|1.2], by turning them into position **45°** (45°, see page 10).
3. Connect a heat-resistant hose to the lowest drain valve of the solar installation (possibly drain valve [3.2]). Make sure that the solar fluid is collected in a heat-resistant container.

	<p style="text-align: center;">WARNING</p> <p>Danger of scalding due to hot solar fluid!!</p> <p>The escaping fluid may be very hot.</p> <ul style="list-style-type: none"> ➤ Place and fix the heat-resistant collecting container so that people standing nearby are not endangered when the solar installation is being emptied.
---	--

4. Open the lowest drain valve of the solar installation.
5. Open a vent valve possibly present at the highest point of the solar installation.
6. Dispose of the solar fluid observing the local regulations.

5.2 Deinstallation



1. Drain the solar installation as described above.
2. Disconnect the pipe connections to the solar system.
3. To remove the solar station from the
4. mounting plate, pull the clips to the side using a screwdriver.

6. Spare parts

NOTICE

Complaints and requests/orders of spare parts will only be processed with information on the serial number. The serial number is placed on the safety group of the solar station.

- In case of a complaint, please send us the entirely completed commissioning report on page 23.

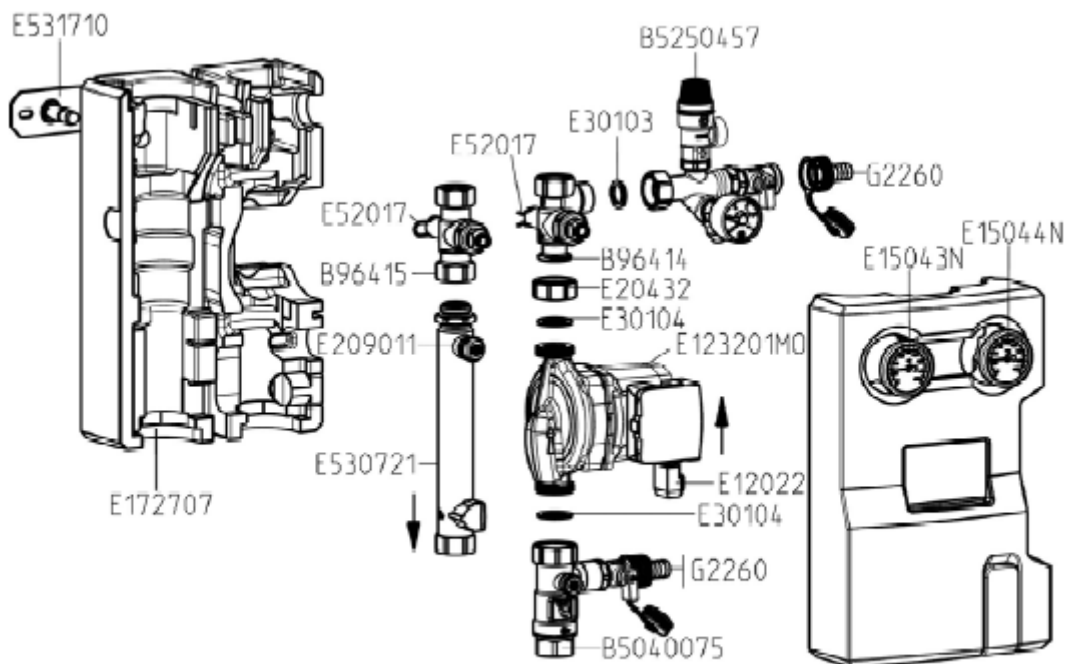

Pump	Item number
Wilos Yonos PARA ST 15/7.5 PWM2	E1232075
Wilos Yonos PARA ST 15/13 PWM2	E12320135

7. Technical data and pressure drop characteristic

Dimensions:	Total height (without controller)	379 mm
	Total width	334 mm
	Depth	150 mm
	Centre distance, flow/return	100 mm
	Pipe connections	¾" internal thread
	Connection for expansion tank	¾" external thread, flat sealing
	Outlet pressure relief valve	¾" internal thread
Operating Data:	Max. admissible pressure	PN 10
	Max. operating pressure	120 °C
	Max. short-time temperature	160 °C, < 15 minutes
	Max. propylen glycol content	50 %
Equipment:	Pressure relief valve	6 bar
	Pressure gauge	0 - 6 bar
	Check valves	2 x 200 mm wc, can be opened
Material:	Valves and fittings	Brass
	Gaskets	EPDM
	Check Valves	Brass
	Insulation	EPP, $\lambda = 0,041 \text{ W}/(\text{m K})$

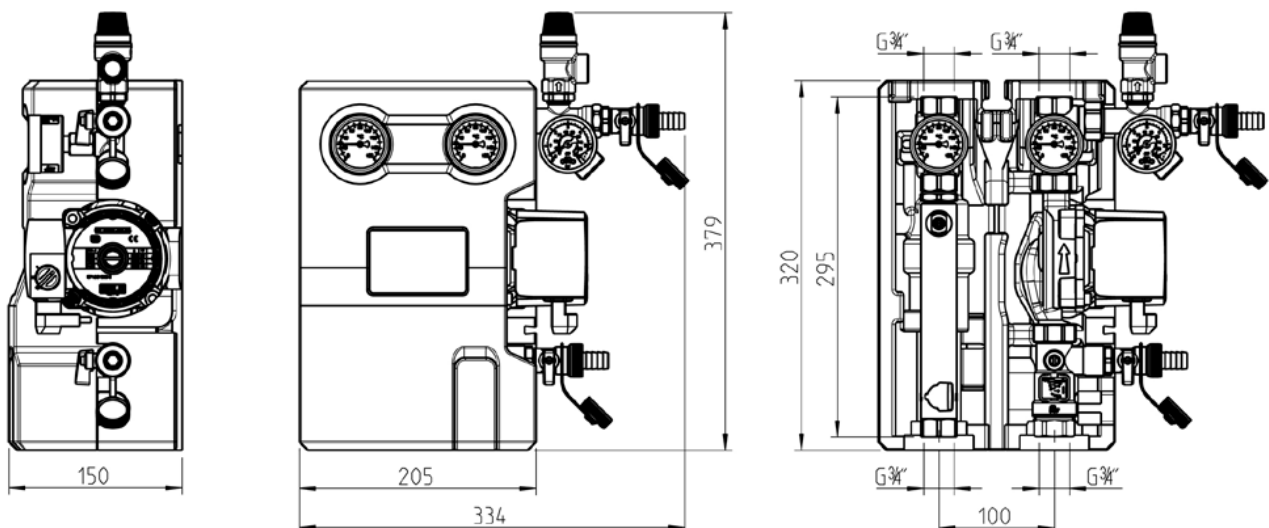

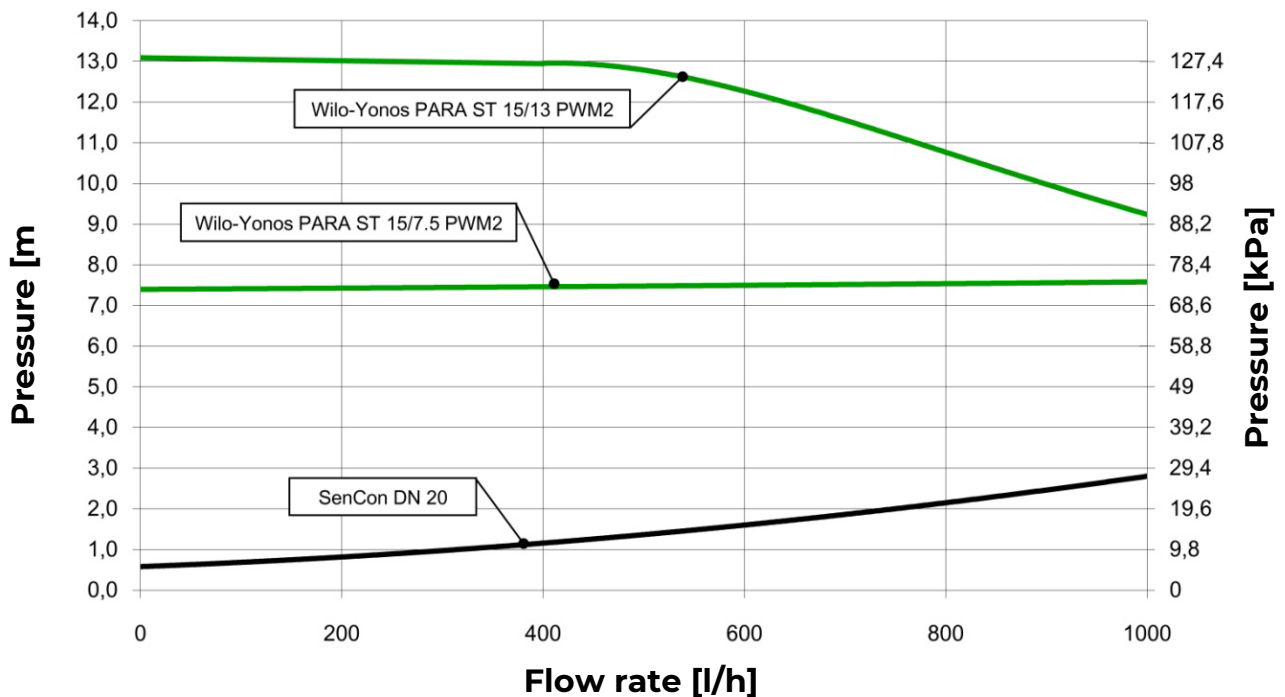

8. Function: check valves

Within their application range, the check valves in this station prevent unwanted gravity circulation. The efficiency of the check valves depends on:

- the installation height
- the temperature difference between the storage tank and the collector
- the type of heat transfer medium

In the diagram below you can see whether the check valves integrated in the station are sufficient. If the check valves are not sufficient, you need to install additional components to prevent gravity circulation. You can mount components such as syphons ("heat traps"), 2-way valves (zone valves) or additional check valves.

Example:

- The station comprises two check valves (2 x 200 mm wc = 400 mm wc).
- You use a mixture of water and 50% of propylene glycol as a solar fluid.
- The installation height between the collector and the storage tank is 10 m.

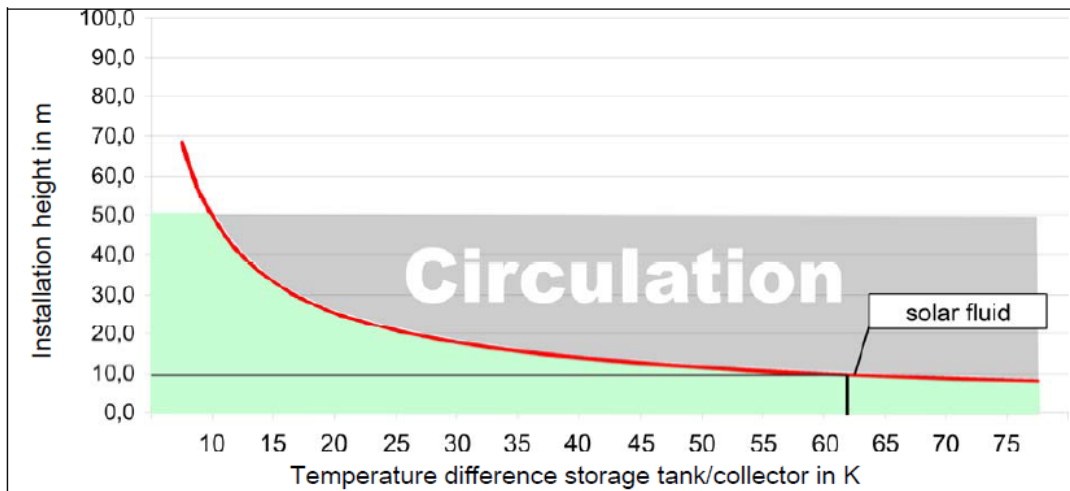

Result:

The check valves prevent gravity circulation up to a temperature difference of **about 62 K**. If the temperature difference between the collector and the tank is larger, the difference in density of the solar fluid will be so large, that the check valves are pushed open.

Do you wish to get further information?



The density of the solar fluid decreases with rising temperature. In high installations with large temperature differences, the difference in density will cause gravity circulation. This circulation can cool down the storage tank.

Calculation example: $\Delta p = \Delta \rho \cdot g \cdot h$

Collector temperature: 5 °C □ Density solar fluid $\rho_1 = 1042 \text{ kg/m}^3$

Storage tank temperature: 67 °C □ Density solar fluid $\rho_2 = 1002.5 \text{ kg/m}^3$

$$\Delta \rho = \rho_1 - \rho_2 = 39.5 \text{ kg/m}^3$$

$$g = 9.81 \text{ m/s}^2$$

Installation height $h = 10 \text{ m}$

$$\Delta p = 3875 \text{ Pa} = 395 \text{ mm wc}$$

The two check valves in the station (2 x 200 mm wc) are sufficient for an installation height of 10 m and a temperature difference between the collector and the tank of up to 62 K.

IMPORTANT: Please pay attention to all planning, installation and commissioning manuals. These documents are available at all times on <http://akotec.eu/downloads/>.

9. Commissioning report

Installation operator _____

Location of installation _____

Collectors (number / type) _____

Collector surface _____m²

Installation height _____m (Height difference station to collector field)

Pipes \varnothing = _____mm l = _____m

Venting (collector field) Manual vent valve Automatic deaerator
 No Vented

Air stop (station) Vented

Solar fluid (type) _____% glycol

Antifreeze tested up to: _____°C

Flow rate _____l/m

Pump (type) _____

Pump speed level (I, II, III) _____

System pressure _____mbar

Expansion tank (type) _____

Initial pressure _____mbar

Pressure relief valve Checked

Check valves Checked

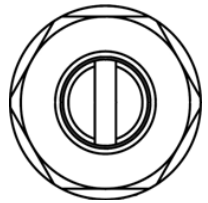
Seriennummern	
Station	
Controller	
Software version	
Restrictor position:	

Plumbing Company

Date, signature